

### Overview and Identification

The Submersible Averaging unit is for duct mounting and temperature measurement of moisture saturated, stratified air across a duct with a humidifier or OSA intake to give the average mixed air temperature along the length of the sensor.

The unit may also be used as a sump sensor to average the water temperature in a water tank. The flexible probe is made of copper and made in different lengths for a custom duct fit. The unit is available in multiple thermistor's or RTD's as shown in the specifications. Enclosure mounting styles come in plastic or metal for both NEMA 1 and NEMA 4 applications and are all plenum rated.

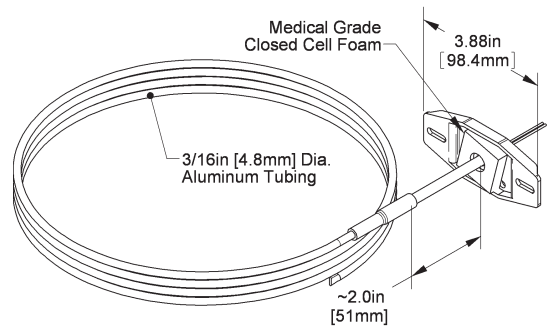

**Fig 1: Duct Unit with No Box (NB)**

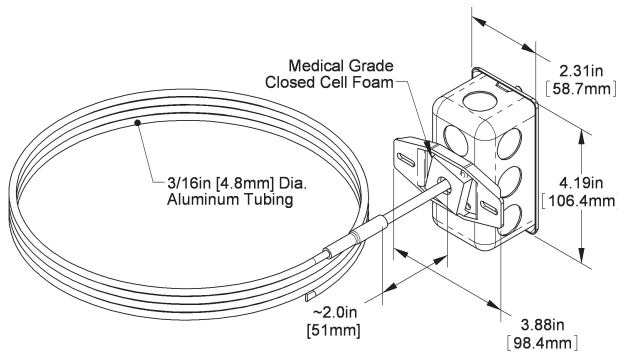

**Fig 2: Duct Unit with J-Box (Standard)**

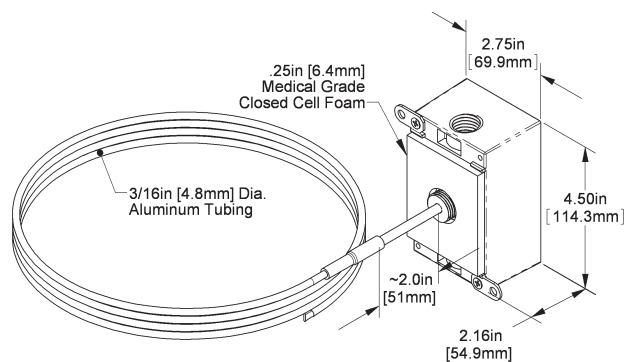

**Fig 3: WeatherProof (WP) Duct Unit**

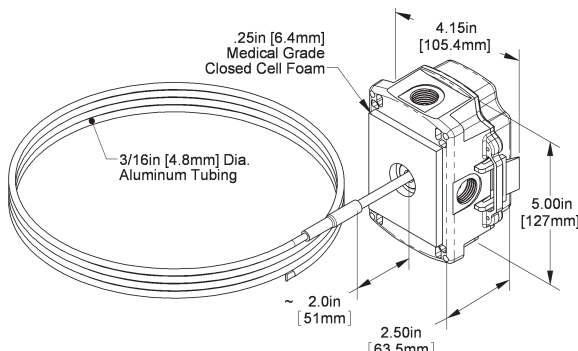

**Fig 4: BAPI-Box (BB) Duct Unit**

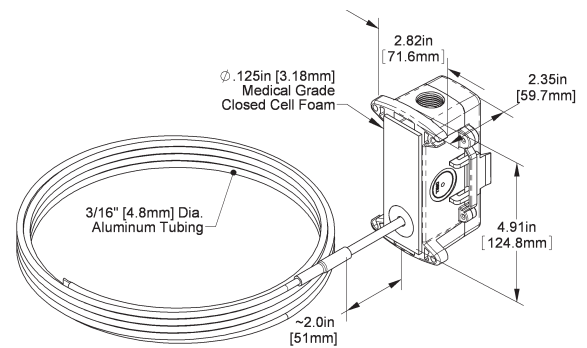

**Fig 5: BAPI-Box 2 (BB2) Duct**

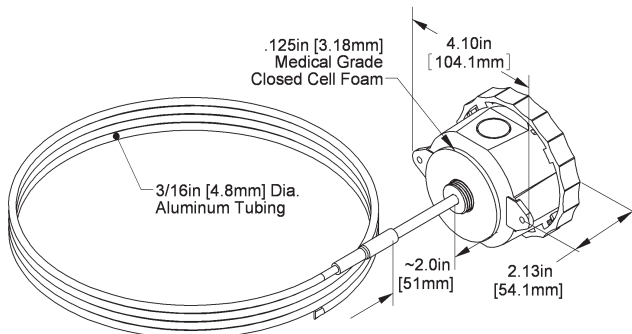

**Fig 6: Weather Tight Enclosure (EU) Duct Unit**

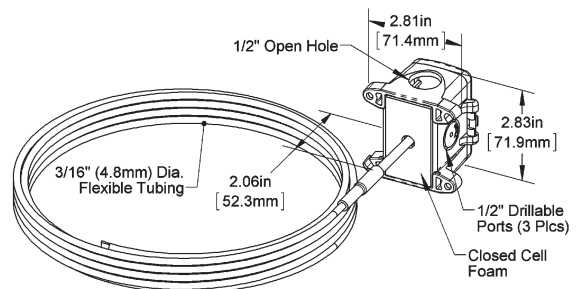

**Fig 7: BAPI-Box 4 (BB4) Duct Unit**

(A Pierceable Knockout Plug is available from BAPI for the open port in the BB4. Part #BA/PAK-100)

Specifications subject to change without notice.

### Mounting

1. Place the sensor in the middle or top of the duct as shown in Fig 8 or Fig 9 so the flexible probe can enter the duct in a convenient place. Drill the probe and mounting holes as depicted for the enclosure being used. (**No Box, Handy Box, BB, BB2, WP, EU, BB4**).
2. Insert the probe by unrolling the sensor into the duct carefully to avoid kinking the sensor. Serpentine the duct with the sensor at least twice across the stratified air in the duct to achieve the best average temperature reading. At the sensor reversing points a turning bracket (BA/FPB) should be used to support the sensor and to avoid kinking the sensor.
3. Mount the enclosure to the duct using BAPI recommended #8 screws through a minimum of two opposing mounting tabs provided. Weatherproof (WP) enclosures will require assembly of the mounting tabs on opposite corners. A 1/8 inch pilot screw hole in the duct makes mounting easier through the mounting tabs. Use the enclosure tabs to mark the pilot hole locations.
4. Snug up the sensors so that the foam backing is depressed to prevent air leakage but do not over-tighten or strip the screw threads.

**Note 1:** Be sure not to drill into the weatherproof enclosures (**BB, BB2, WP, EU, EUO**) which will violate the NEMA and/or the IP rating.

**Note 2:** Be sure to use caulk or Teflon tape for your conduit entries to maintain the appropriate NEMA or IP rating for your application.

**Note 3:** Conduit entry for outdoor or wet applications should be from the bottom of the enclosure.

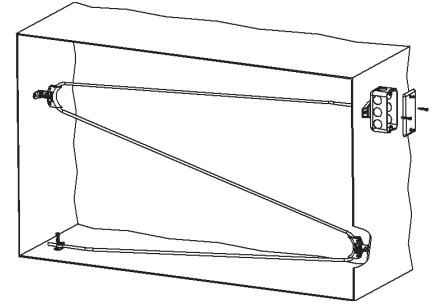

**Fig 8:** Flexible Sensor Horizontal Mount (Best for Vertical Stratification)

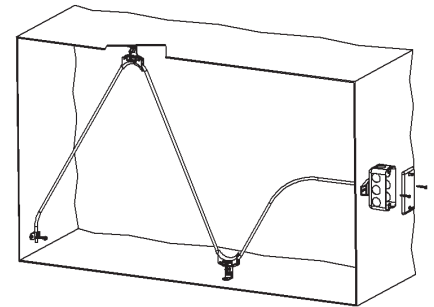

**Fig 9:** Flexible Sensor Vertical Mount (Best for Horizontal Stratification)

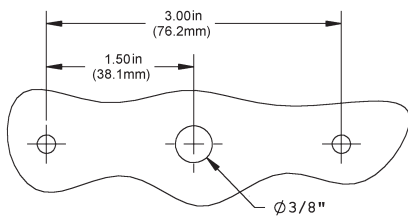

**Fig 10:** Junction Box or No Box (**NB**) Mounting Holes and installation

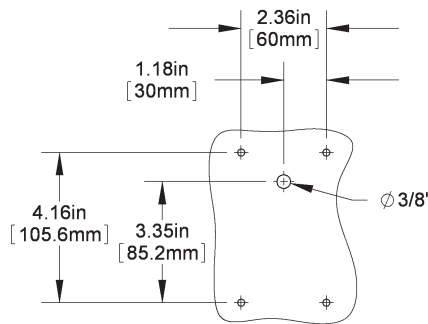

**Fig 11:** BAPI-Box 2 (**BB2**) Mounting Holes and installation.

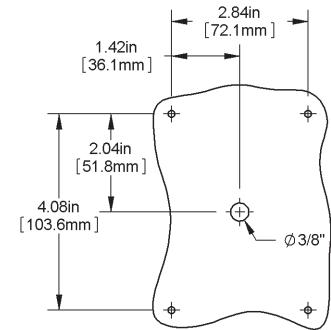

**Fig 12:** BAPI-Box (**BB**) Enclosure Mounting and installation Holes (Rotate 90° for Horizontal Mounting)

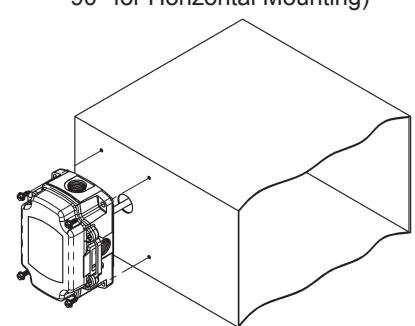
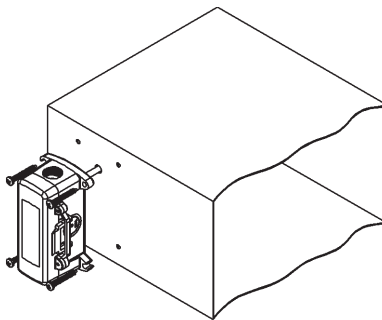
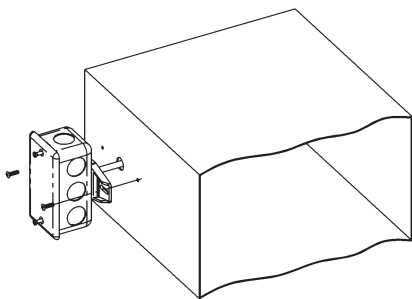

### Mounting continued...

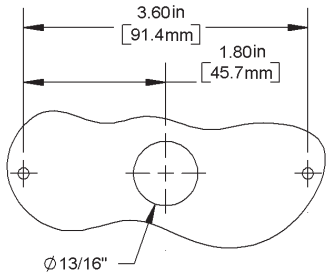

**Fig 13: Weather Tight EU or EUO Encl. Mounting Holes and Installation**

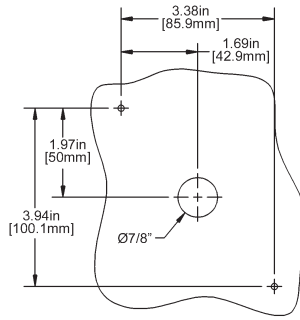
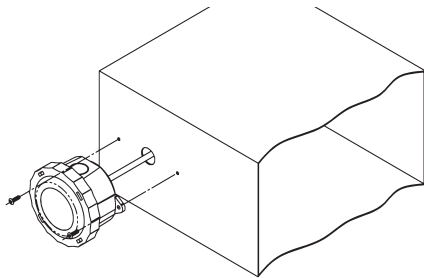

**Fig 14: Weatherproof Box WB Mounting Holes and Installation**

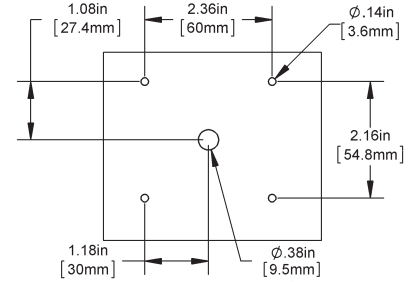
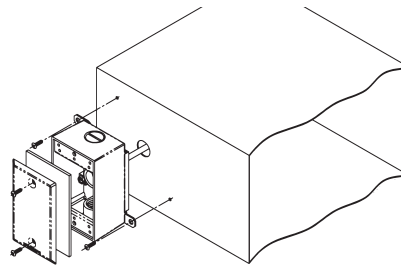

**Fig 15: BAPI-Box 4 (BB4) Enclosure Mounting Holes and Installation**

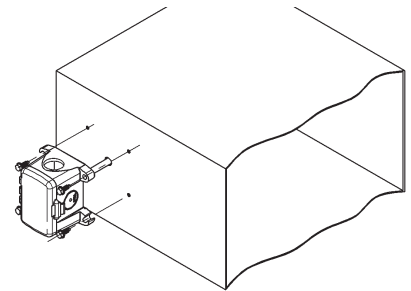

### Wiring & Termination

BAPI recommends using twisted pair of at least 22AWG and sealant filled connectors for all wire connections. Larger gauge wire may be required for long runs. All wiring must comply with the National Electric Code (NEC) and local codes. Do NOT run this device's wiring in the same conduit as high or low voltage AC power wiring.

BAPI's tests show that inaccurate signal levels are possible when AC power wiring is present in the same conduit as the sensor wires.

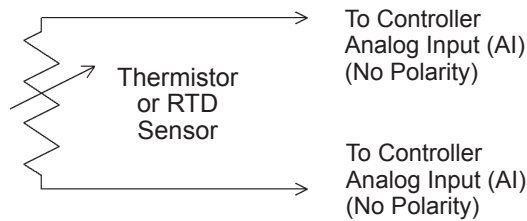

**Fig. 16: 2 Wire Lead Wire Termination for Thermistor or RTD**

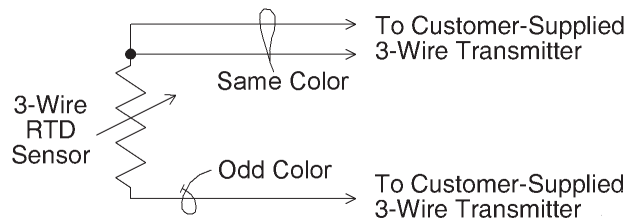

**Fig. 17: 3 Wire Lead Wire Termination for RTD**

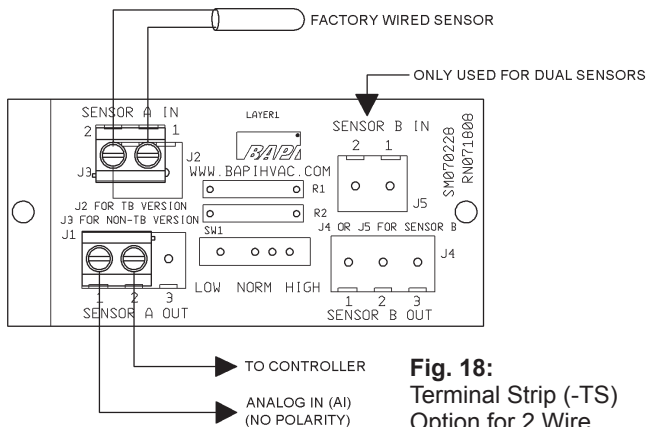

**Fig. 18: Terminal Strip (-TS) Option for 2 Wire Sensors Termination**

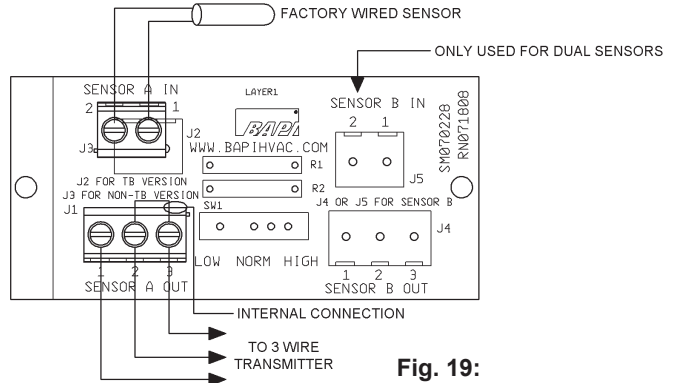

**Fig. 19: Terminal Strip (-TS) Option for 3 Wire Sensors Termination**

Specifications subject to change without notice.

### Wiring & Termination continued...

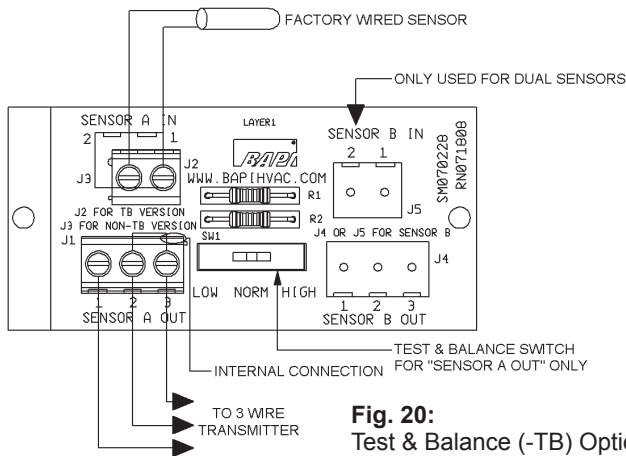

**Fig. 20:**  
Test & Balance (-TB) Option  
for 2 Wire Sensors Termination

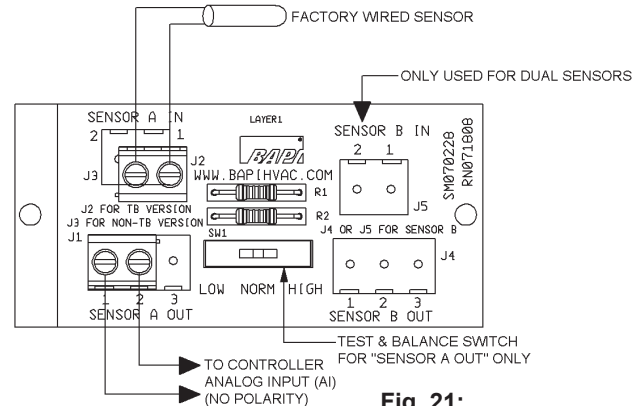

**Fig. 21:**  
Test & Balance (-TB)  
Option for 3 Wire Sensors  
Termination

### Diagnostics

#### Problems:

Controller reports higher or lower than actual temperature.

#### Possible Solutions:

- Confirm the input is set up correctly in the front end software
- Check wiring for proper termination & continuity. (shorted or open)
- Disconnect wires and measure sensor resistance and verify the "Sensor" output is correct.

### Specifications

<b>Sensor</b>	Passive
Thermistor	4 sensors in < 24' probes
	9 sensors in ≥ 24' probes
RTD	Continuous sensor, 2 or 3 wire
<b>Thermistor</b>	Thermal resistor (NTC)
Temp. Output	Resistance per order
Accuracy	(std) ±0.36°F, (±0.2°C)
Accuracy	(Hi) ±0.18°F, (±0.1°C), [XP] option
Stability	< 0.036°F/Year, (<0.02°C/Year)
Heat dissipation	2.7 mW/°C
Temp. Drift	<0.02°C per year
Probe range	-40° to 221°F (-40° to 105°C)
<b>RTD</b>	Resistance Temp Device (PTC)
Platinum (Pt)	100Ω and 1KΩ @0°C, 385 curve
Platinum (Pt)	1KΩ @0°C, 375 curve
Pt Accuracy (std)	0.12% @Ref,
	or ±0.55°F, (±0.3°C)
Pt Stability	±0.25°F, (±0.14°C)
Pt Self Heating	0.4 °C/mW @0°C
Pt Probe range	-40° to 221°F, (-40 to 105°C)
Nickel (Ni)	1000Ω @70°F, JCI curve
Ni Probe range	-40° to 221°F (-40 to 105°C)
<b>Sensitivity</b>	Approximate
Thermistor	Non-linear (Go to bapihvac.com for specs)
RTD (Pt)	3.85Ω/°C for 1KΩ RTD
	0.385Ω/°C for 100Ω RTD
Nickel (Ni)	2.95Ω/°F for the JCI RTD
<b>Lead Wire</b>	22awg stranded, etched teflon, Plenum rated
<b>Probe</b>	Flexible Copper Tube, 0.19" OD
<b>Probe Length</b>	2', 4' or 8' per order
<b>Duct Gasket</b>	1/4" Closed cell foam (impervious to mold)
<b>Mounting</b>	Extension tabs (ears), 3/16" holes
<b>Water Seal</b>	Teflon Coated Sensors and Heat Sealed at Both Ends

#### Enclosure Types

J-Box  
No Box  
Weather Proof  
BAPI-Box  
BAPI-Box 2  
BAPI-Box 4:  
Weather Tight

-JB, w/eight 1/2" knockouts  
-NB, intended for open wiring  
-WP, w/ two 1/2" FNPT entries, (Bell box)  
-BB, w/four 1/2" NPSM & one 1/2" drill-out  
-BB2, w/three 1/2" NPSM & three 1/2" drill-outs  
-BB4, w/ three 1/2" drill-outs & one 1/2" open port  
-EU, -EUO, w/two 1/2" knockouts

#### Enclosure Ratings

J-Box  
No Box  
Weather Proof  
BAPI-Box  
BAPI-Box 2  
BAPI-Box 4:  
Weather Tight

-JB, NEMA 1  
-NB, No rating  
-WP, NEMA 3R, IP14  
-BB, NEMA 4X, IP66  
-BB2, NEMA 4X, IP66  
-BB4, IP44 (IP44 with Knockout Plug installed)  
-EU, -EUO, NEMA 4X, IP66 (EUO is UV-rated)

#### Enclosure Materials

J-Box  
No Box  
Weather Proof  
BAPI-Box  
BAPI-Box 2  
BAPI-Box 4:  
Weather Tight  
Weather Tight

-JB, Galvanized steel, UL94H-B  
-NB, Nylon 66, UL94H-B  
-WP, Cast Aluminum, UV rated  
-BB, Polycarbonate, UL94V-0, UV rated  
-BB2, Polycarbonate, UL94V-0, UV rated  
-BB4, Polycarbonate & Nylon, UL94V-0  
-EU, ABS Plastic, UL94V-0  
-EUO, ABS Plastic, UL94V-0, UV rated

#### Ambient (Encl.)

All BAPI-Boxes  
Weather Tight  
J-Box & No Box  
Weatherproof

0 to 100% RH, Non-condensing  
-BB, BB2, BB4, -40°F to 185°F, (-40° to 85°C)  
-EUO, EU, -40°F to 185°F, (-40° to 85°C)  
-JB, NB, -40°F to 212°F, (-40° to 100°C)  
-WP, -40°F to 212°F, (-40° to 100°C)

#### Agency

RoHS, \*CE  
PT=DIN43760, IEC Pub 751-1983,  
JIS C1604-1989  
\*Passive Thermistors 20KΩ and smaller are CE

Specifications subject to change without notice.